

CHAPTER 8

STEERING

STEERING WHEEL	8— 1
STEERING GEAR BOX	8— 7
STEERING LINKAGE	8—12

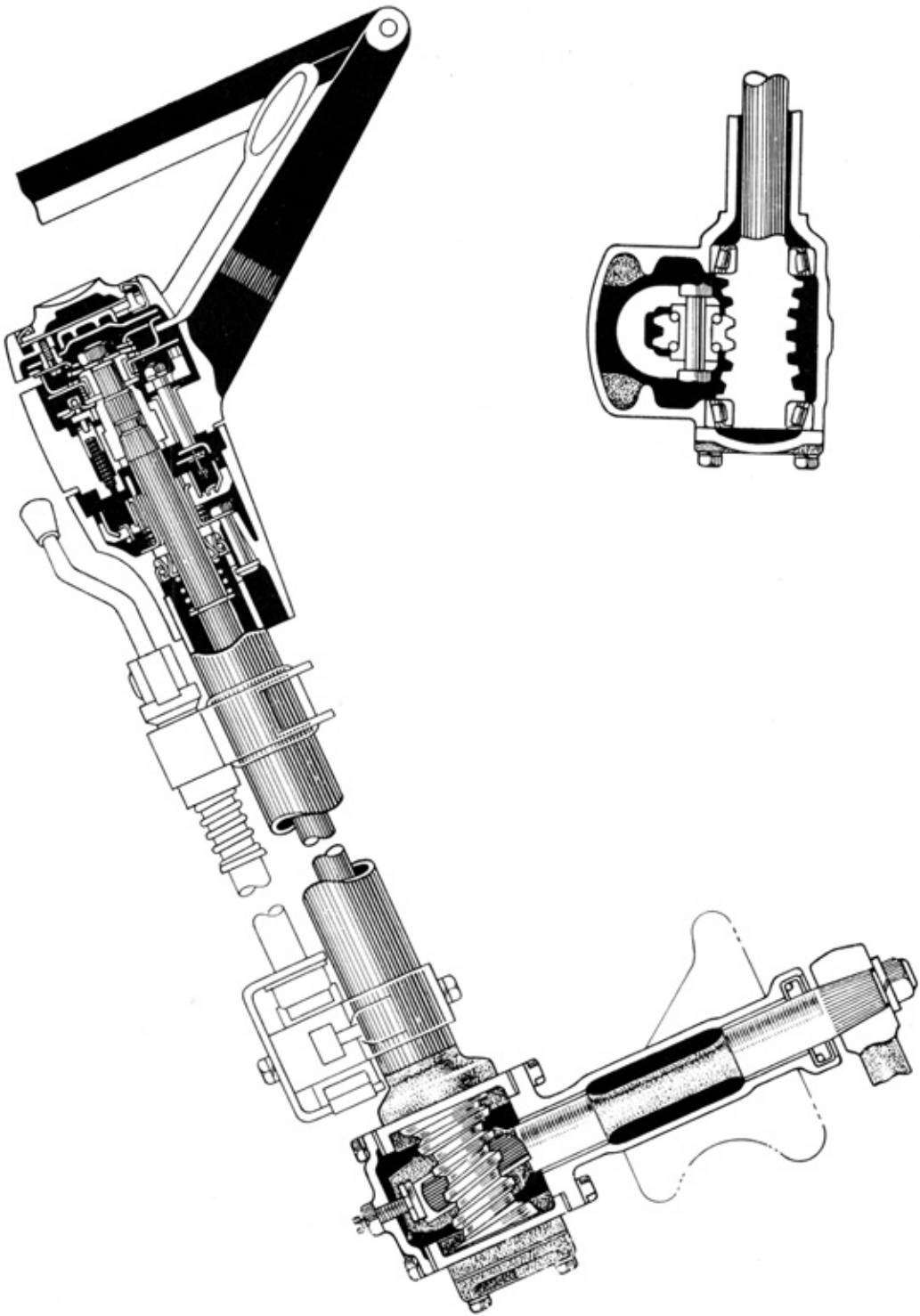

Fig. 8-1 Section of Steering

STEERING WHEEL

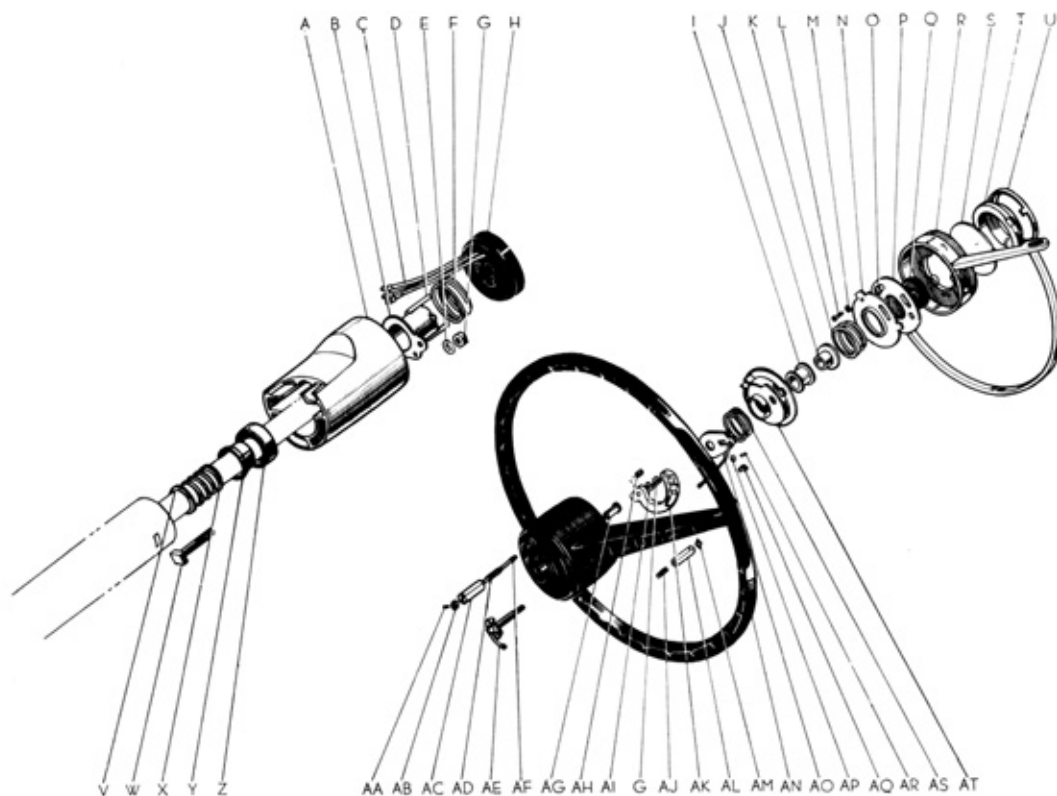

Fig. 8-2 Steering Wheel

- | | |
|--------------------------------------|--|
| A Contact Ring Housing | X Main Shaft Bearing Thrust Spring |
| B Contact Ring Retainer | Y Main Shaft Bearing Thrust Collar |
| C Signal Wire | Z Steering Main Shaft Bearing Complete |
| D Turn Signal Auto Return Pin | AA Horn Contact Roller Pin |
| E Washer | AB Horn Contact Roller |
| F Contact Ring Complete Set Spring | AC Horn Contact Roller Holder |
| G Nut | AD Horn Contact Roller Spring |
| H Contact Ring Complete | AE Turn Signal Auto Return Complete |
| I Turn Signal Plate Bushing | AF Horn Button Wire |
| J Steering Wheel Set Spacer | AG Turn Signal Shaft Bushing |
| K Wheel Spring | AH Turn Signal Both Collar |
| L Screw | AI Spring Washer |
| M Washer | AJ Turn Signal Click Stop Spring |
| N Horn Button Stop Plate | AK Turn Signal Operating Arm |
| O Horn Button Set Washer | AL Click Stop Roller Holder |
| P Horn Button Contact Plate Complete | AM Click Stop Roller |
| Q Horn Button Cushion Rubber | AN Steering Wheel Complete |
| R Steering Horn Ring | AO Thrust Stop Plate |
| S Horn Button Back Plate | AP Thrust Stop Roller |
| T Horn Button | AQ Thrust Stop Roller Holder |
| U Horn Button Stopper Ring | AR Thrust Stop Roller Pin |
| V Main Shaft Snap Ring | AS Horn Earth Spring |
| W Contact Ring Housing Set Bolt | AT Horn Button Contact Seat Complete |

Removal

1. Disconnect turn signal wire and horn wire.
2. Press center of the horn ring and twist it in counterclockwise direction. Then remove horn ring from steering wheel.

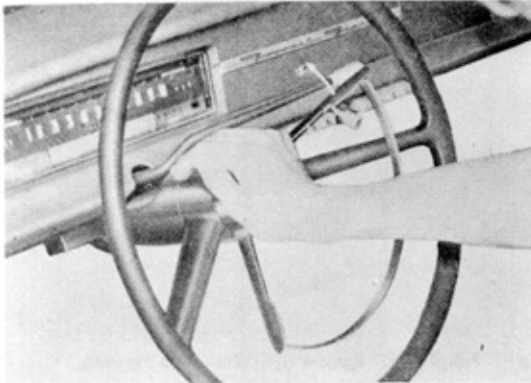

Fig. 8-3 Removing Horn Ring

3. Disconnect horn button wire and remove horn spring.

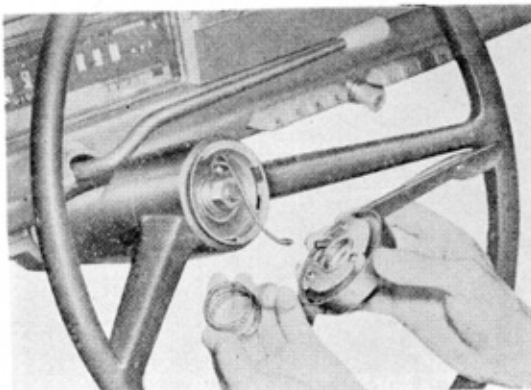

Fig. 8-4 Removing Horn Spring

4. Remove nut attaching steering wheel to upper end of main shaft.

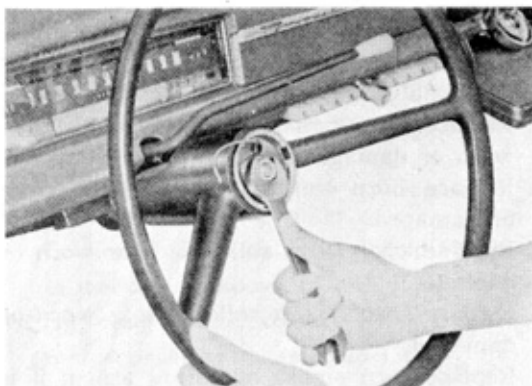

Fig. 8-5 Removing Main Shaft Nut

5. Take out horn button contact seat.

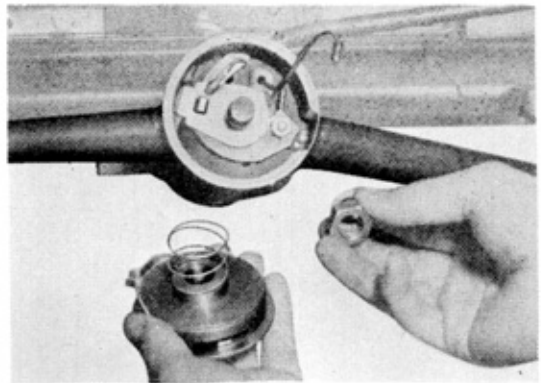

Fig. 8-6 Taking out Contact Seat

6. Take out horn earth spring and thrust stop plate.

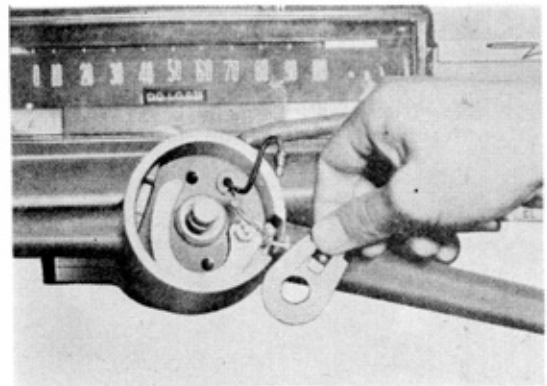

Fig. 8-7 Taking out Thrust Stop Plate

7. Remove steering wheel using Steering Wheel Puller (RT20 SST-2081).

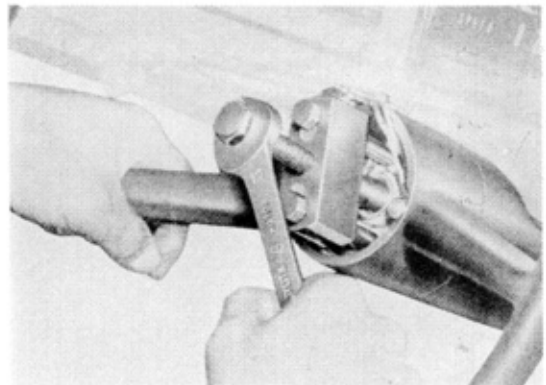

Fig. 8-8 Removing Steering Wheel

8. Disassemble steering wheel.
 - a. Pull out horn contact roller.
 - b. Remove turn signal operating plate and auto return.

c. Pull out click stop roller.

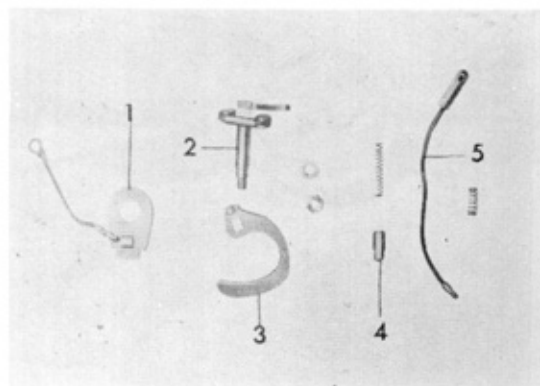

Fig. 8-9

1. Thrust Stop Plate
2. Turn Signal Auto Return
3. Turn Signal Operating Arm
4. Click Stop Roller
5. Horn Contact Roller

9. Press down contact ring and twist in counterclockwise direction.

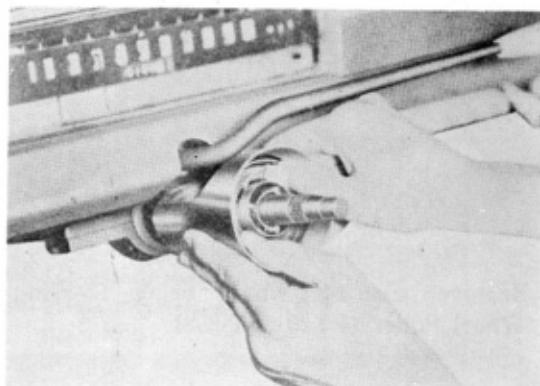

Fig. 8-10 Twisting Contact Ring

10. Then remove contact ring.

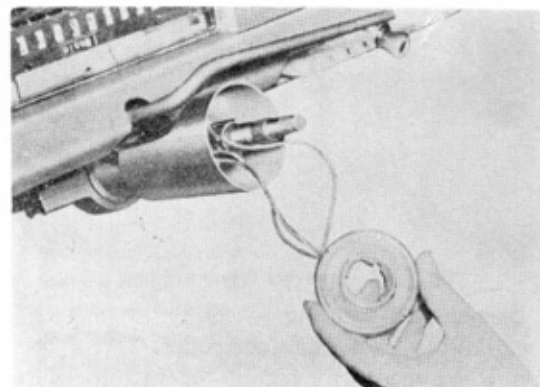

Fig. 8-11 Removing Contact Ring

11. Take out contact ring set spring.
12. Remove contact ring housing set bolt, and take out contact ring retainer.
13. Remove contact ring housing.

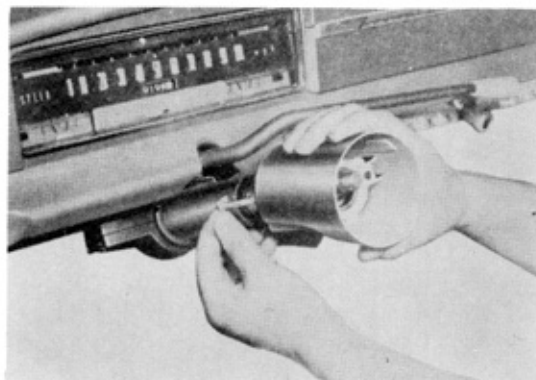

Fig. 8-12 Removing Contact Ring Housing

14. Pull out main shaft bearing thrust collar and spring from contact ring housing.

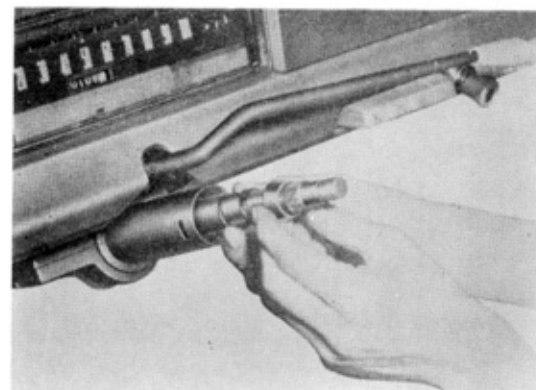

Fig. 8-13 Removing Collar and Spring

Inspection

1. Replace horn button cushion rubber if it is damaged or deformed.
2. Replace horn button set washer if it is damaged or defective in insulation.
3. Replace turn signal plate bushing if it is worn or damaged.
4. Replace horn contact roller if it is worn or damaged.
5. Replace click stop roller if it is worn or damaged.
6. Replace thrust stop roller if it is worn or damaged.
7. Replace turn signal operating arm if it is worn or damaged.

8. Replace turn signal auto return complete if it is bent or worn.
9. Replace contact ring if it is worn or damaged.
10. Replace main shaft bearing if it is worn, scored or noisy.
11. Replace horn spring or main shaft bearing thrust spring if they are weakened.

Installation

1. Install main shaft bearing collar and spring into contact ring housing.
2. Assemble contact ring housing to mast jacket.
 - a. Insert set bolts to contact ring housing from lower side.
 - b. Project the thread part of set bolt about 0.2" from the housing inner surface and then fix the set bolt with "dum-dum" to prevent fall-out.
 - c. Install contact ring housing on mast

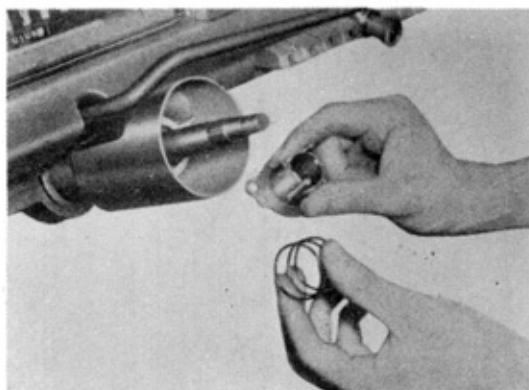

Fig. 8-14 Assembling Retainer and Spring

jacket.

- d. Assemble contact ring retainer into contact ring housing.
And tighten two nuts attaching contact ring housing to mast jacket.

Torque Spec. 0.5~0.6 m-kg (3.6~4.6 ft-lb).

3. Install contact ring set spring.
4. Install contact ring.
5. Assemble steering wheel.

- a. Install click stop roller.

Caution: Clip stop roller should be placed in the center groove of turn signal operating arm, and a contact point should not contact inner or outer contact ring.

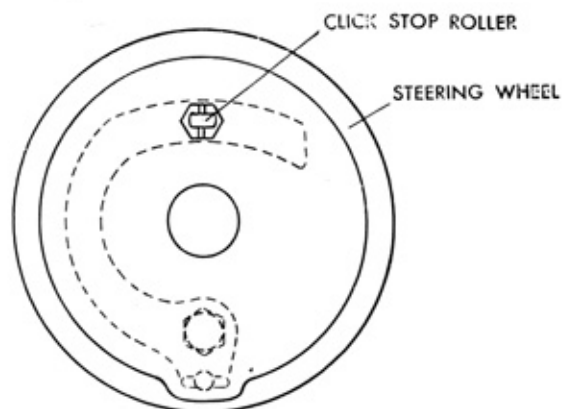

Fig. 8-15 Installing Click Stop Roller

- b. Insert turn signal auto return into steering wheel, and install turn signal operating arm and thrust stop plate.
Then tighten nut attaching turn signal operating arm to steering wheel.

Torque Spec. 0.7~0.8 m-kg (5~5.8 ft-lb)

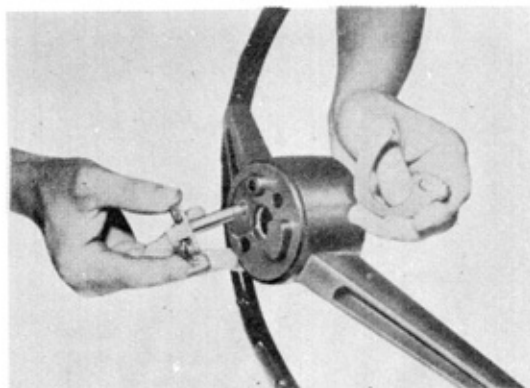

Fig. 8-16 Inserting Auto Return

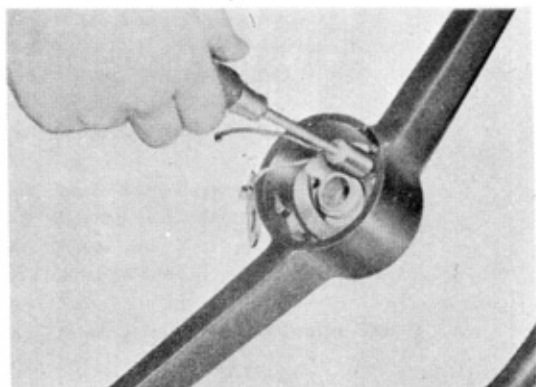

Fig. 8-17 Installing Operating Arm

c. Install horn contact roller.

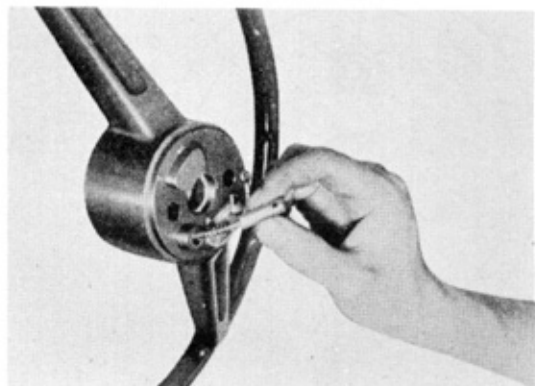

Fig. 8-18 Installing Horn Contact Roller

6. Install steering wheel.

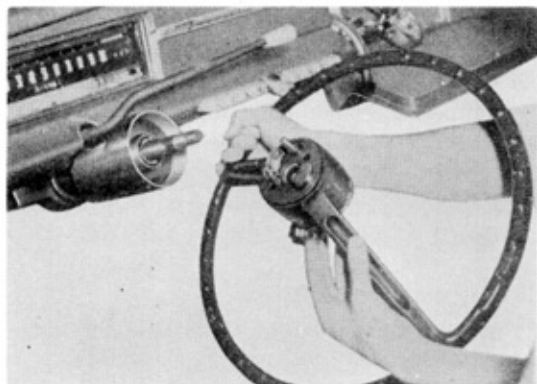

Fig. 8-19 Installing Steering Wheel

7. Install horn earth spring.
8. Install horn button contact seat, and tighten nut attaching steering wheel to upper end of main shaft.
Torque Spec. 8~9 m·kg (58~65 lb·ft).
9. Install horn spring.
10. Connect horn button wire.
11. Install horn ring.
12. Connect horn wire and turn signal wire.

STEERING GEAR BOX

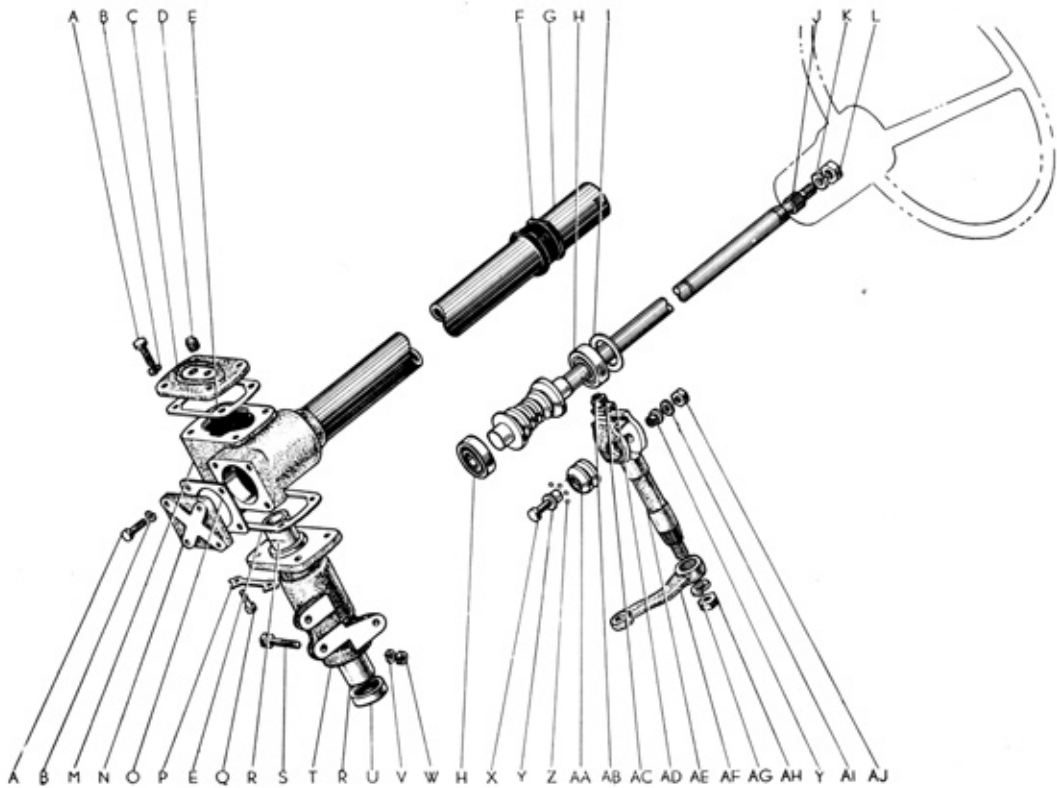

Fig. 8-20 Steering Gear Box

- | | |
|--|--|
| A Bolt | S Bolt |
| B Spring Washer | T Steering Gear Box Bracket |
| C Sector Shaft End Cover | U Sector Shaft Oil Seal |
| D Steering Gear Box Oil Plug | V Spring Washer |
| E Steering Gear Box Packing | W Nut |
| F Steering Column Clamp Grommet | X Steering Sector Roller Shaft |
| G Mast jacket | Y Sector Roller Ball Bearing Inner Race |
| H Steering Worm Front Taper Roller Bearing | Z Steering Sector Roller Ball |
| I Steering Worm Front Bearing Adjusting Shim | AA Steering Sector Roller |
| J Steering Main Shaft Complete | AB Sector Shaft Adjusting Bolt |
| K Spring Washer | AC Nut |
| L Nut | AD Sector Shaft Thrust Plate |
| M Steering Gear Box | AE Steering Sector Shaft |
| N Steering Worm Bearing Cap | AF Pitman Arm |
| O Steering Worm Bearing Cap Packing | AG Spring Washer |
| P Steering Gear Box Bracket Bolt Lock | AH Nut |
| Q Bolt | AI Steering Sector Roller Adjusting Shim |
| R Sector Shaft Bushing | AJ Nut |

Removal

1. Remove steering wheel and related parts. (See page 8-2 "STEERING WHEEL".)
2. Remove backup light switch.

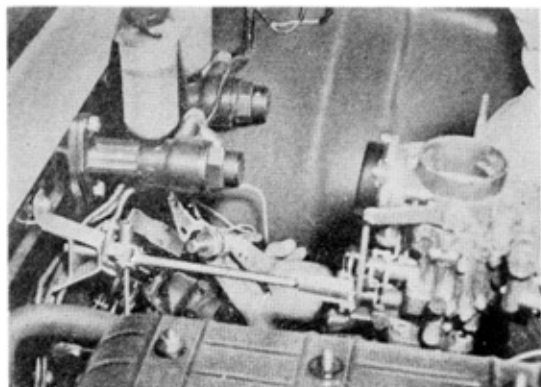

Fig. 8-21 Removing Backup Light Switch

3. Remove transmission control rod.
4. Remove pitman arm using Pitman Arm Puller (PT20 SST-2082).
5. Remove brake pedal.
6. Remove control shaft upper bracket from the instrument panel.
7. Remove mast jacket hole cover.

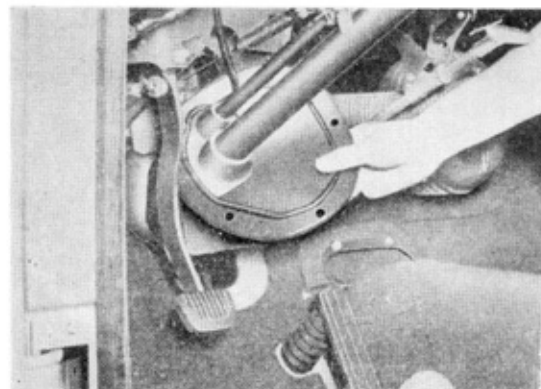

Fig. 8-22 Removing Hole Cover

8. Remove set bolts on steering gear box bracket.
9. Pull steering gear box with control shaft to inward.
Note: Take care not to drop gear oil to the room.
10. Remove control shaft and related parts from the mast jacket.

Installation

Follow "REMOVAL" in reverse order.

Note:

1. Install pitman arm to the sector shaft mating marks.
 (See page 8-12 "STEERING LINKAGE".)
2. After installing, check to see if the oil is up to the filler hole. Replenish if found low.

Disassembly

1. Remove steering mast jacket.
2. Remove four bolts attaching sector shaft end cover.

Loosen nut and screw in sector shaft adjusting bolt, slide end cover along the groove provided at the top end of the groove of the sector shaft, and remove end cover with adjusting bolt and thrust plate attached.

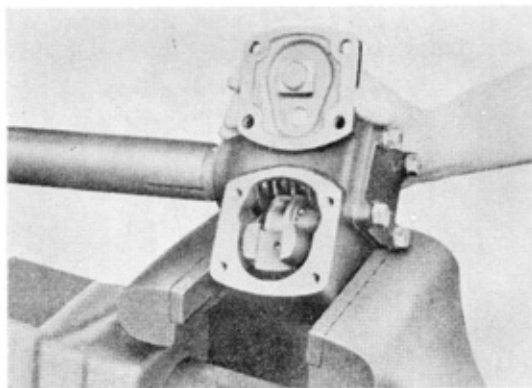

Fig. 8-23 Removing End Cover

3. Pull out sector shaft.

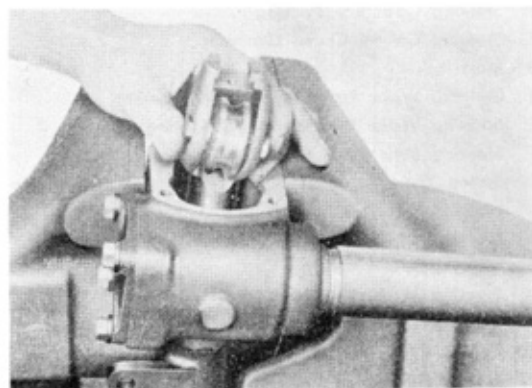

Fig. 8-24 Pulling out Sector Shaft

4. Remove steering worm bearing cap.

5. Remove steering worm lower bearing cup.

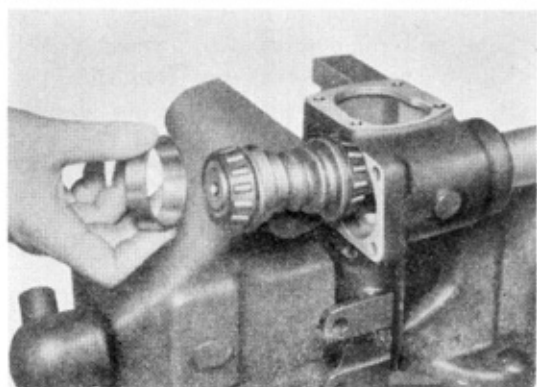

Fig. 8-25 Removing Lower Bearing Cup

6. Pull out steering main shaft.
7. Remove steering worm upper and lower bearing cone from the steering main shaft using Steering Worm Bearing Cone Remover (RS SST-2086).

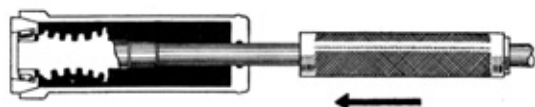

Fig. 8-26 Removing Lower Bearing Cone



Fig. 8-27 Removing Upper Bearing Cone

8. Remove steering worm upper bearing cup from the gear box using Bearing Puller (FQ15 SST-2084).

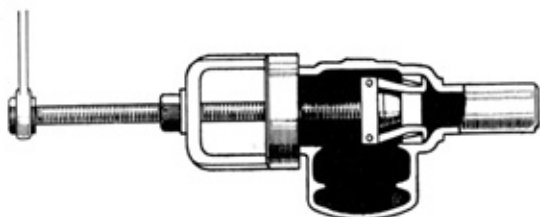

Fig. 8-28 Removing Upper Bearing Cup

9. Remove steering gear box bracket.

Inspection

1. Inspect the following points of steering main shaft.
If found defective, replace with new one.

- a. Deformation of main shaft.
 - b. Excessive wear and score of steering worm.
 - c. Score of serration.
2. Inspect the following points of sector shaft.
If found defective, replace with new one.
- a. Wear of sector roller.
 - b. Wear and score of sector roller ball.
 - c. Wear of sector shaft.
 - d. Score of serration.
3. Check fitting condition between sector shaft thrust plate and slot of sector shaft.

Note: Thrust plates are available in two different thickness.

Thickness of Sector Shaft Thrust Plate.

No.1	2.9 mm (0.114")
No.2	3.0 mm (0.126")

4. Measure clearance between sector shaft and sector shaft bushing.
If it is more than 0.2 mm (0.08"), replace sector shaft bushing.

Note:

Standard Clearance

0.01~0.05 mm (0.04"~0.020")

Diameter of Sector Shaft

28 mm (1.2")

5. Replace mast jacket if it is bent or damaged.
6. Replace gear box bracket if it is cracked or damaged.
7. Replace worm bearing if it is worn, scored or noisy.
8. Replace oil seal if it is damaged or oil leaked.

Assembly

1. Install gear box bracket to the gear box.
Torque Spec. 2.5~2.8 m-kg (18~20ft-lb)
2. Install steering worm upper bearing cup into steering gear box.
When assembling, place necessary number of bearing adjusting shims between the bearing cup and the gear box so that the center of worm align with the pivoting center of sector shaft. (See page 8-11,10.)
3. Install steering worm upper and lower bearing cone to the steering worm.
4. Install steering main shaft in the steering gear box, then install steering worm lower bearing cup.

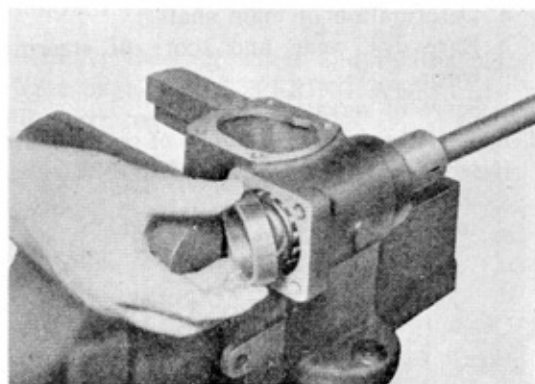

Fig. 8-29 Installing Lower Bearing Cup

5. Attach steering worm bearing cap to steering gear box with cap packing inserted in between.



Fig. 8-30 Installing Bearing Cap & Packings

6. WORM BEARING PRELOAD ADJUSTMENT

Adjust preload of worm bearing using cap packings. Place one packing and tighten cap to specified torque. Attach steering wheel temporarily. Apply spring scale to a spoke at a rim of wheel and exert a steady

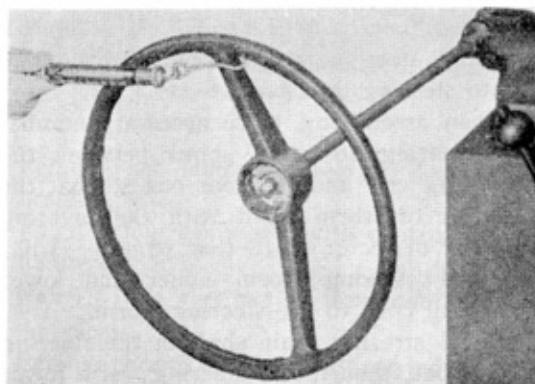

Fig. 8-31 Measuring Preload of Worm Bearing

pull while keeping the scale at 90 degrees to spoke as shown in the figure.

The pull required to keep wheel turning slowly should be between $\frac{1}{2}$ lb and 1 lb.

If preload is excessive, increase thickness of packing.

If preload is not enough, decrease thickness of packing.

Worm bearing cap packings are available in two different thickness.

Thickness of Bearing Cap Packing

No. 1 0.5 mm (0.020")

No. 2 0.2 mm (0.008")

7. Install steering sector shaft in the gear box so that sector roller meshes with worm gear approximately at the center.

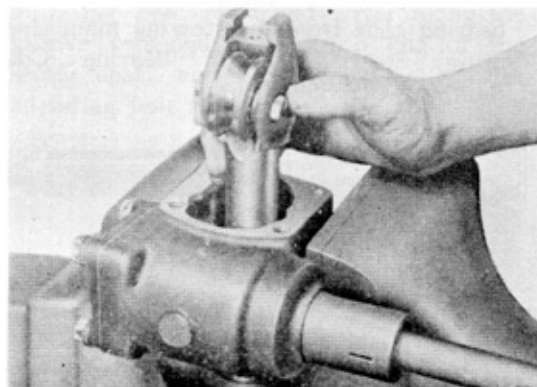

Fig. 8-32 Installing Sector Shaft

8. Slide thrust plate into the slot at the head of the sec shaft with adjusting bolt, and install sector shaft end cover to the gear box.

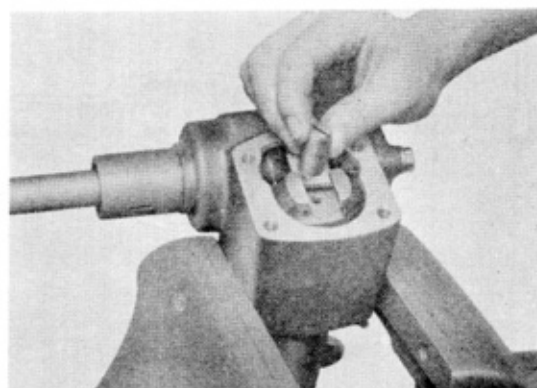

Fig. 8-33 Sliding Thrust Plate

Torque Spec. 2.5~2.8 m·kg (18~20 ft·lb)

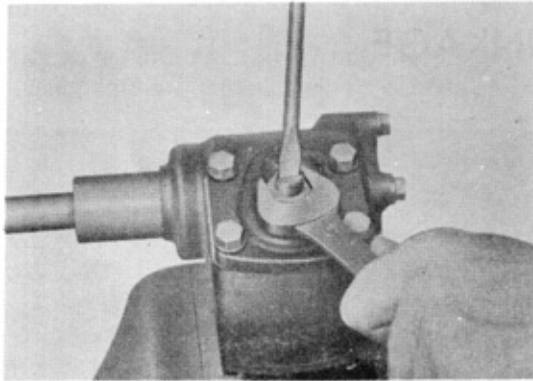

Fig. 8-34 Installing End Cover

Caution: When attaching end cover, sector shaft adjusting bolt must be turned counter-clockwise all the way beforehand to avoid cracking end cover.

9. SECTOR SHAFT BACKLASH ADJUSTMENT

First turn steering wheel gently from one extreme to the other, carefully counting the total number of turns.

Then turn wheel back exactly half way, which is the central position.

Adjust sector shaft backlash with sector shaft adjusting bolt so that steering wheel may have 0 to 15 mm (0 to 0.6") play.

10. If there is any difference in play or stiffness between right and left when turning the steering wheel, make following adjustment using steering worm bearing adjusting shims.

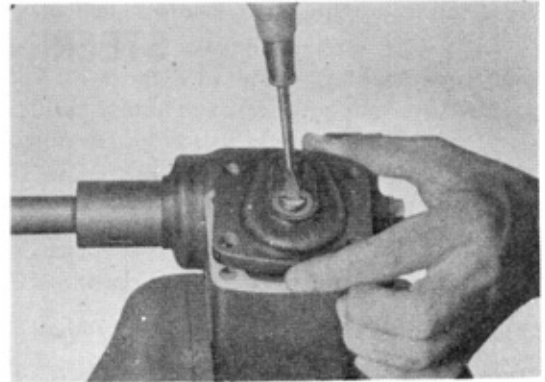

Fig. 8-35 Adjusting Sector Shaft Backlash

Thickness of Adjusting Shim

KB 4507-1	0.5 mm (0.020")
KB 4507-2	0.2 mm (0.008")
KB 4507-3	0.1 mm (0.004")

1. If play decreases or stiffness increases as the steering wheel is turned to the right, adjust by reducing bearing adjusting shims.
2. If play decreases or stiffness increases as the steering wheel is turned to the left, adjust by increasing bearing adjusting shims.

Note: If there is any difference in play or stiffness between right and left when turning the steering wheel, it means that the center line of the worm gear is not aligned with the pivoting center of the sector shaft.

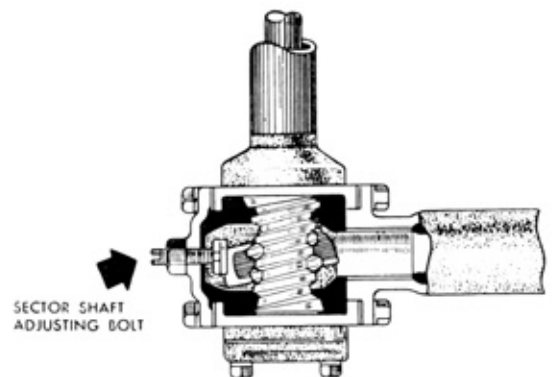
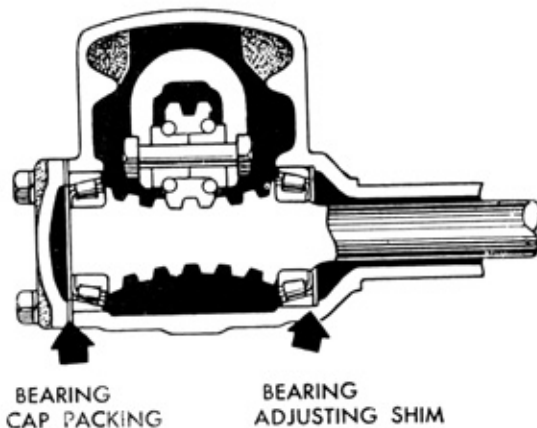

Fig. 8-36 Section of Steering Gear Box

STEERING LINKAGE

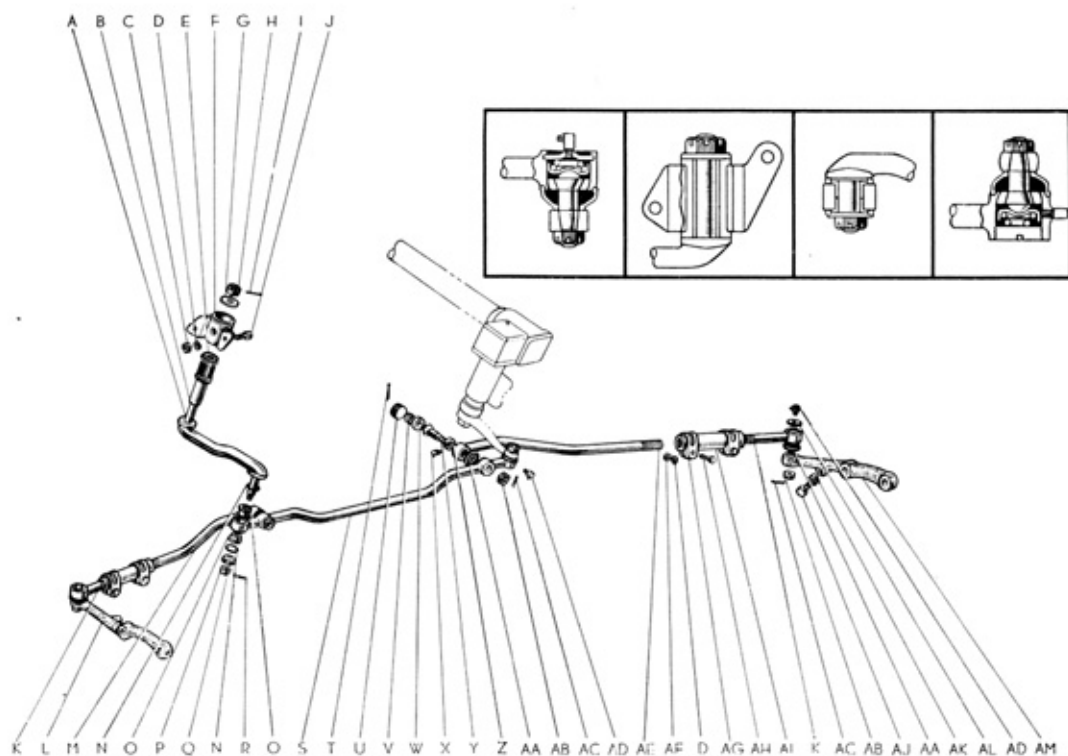

Fig. 8-37 Steering Linkage

- | | |
|--|----------------------------------|
| A Steering Idler Arm | V Tie-rod Spring |
| B Idler Arm Bushing Inner Pipe | W Tie-rod End Ball Seat |
| C Nut | X 67.5° Bend Small Grease Nipple |
| D Spring Washer | V Spring Washer |
| E Steering Idler Arm Rubber Bushing | W Nut |
| F Steering Idler Arm Support Complete | X Steering Sector Roller Shaft |
| G Steering Idler Arm Rubber Bushing Washer | Y Tie-rod End Knob |
| H Nut | Z Tie-rod End Ball |
| I Cotter Pin | AA Tie-rod End Dust Seal |
| J Bolt | AB Steering Knuckle Arm Knob Nut |
| K Tie-rod End | AC Cotter Pin |
| L Steering Knuckle Arm | AD 90° Bend Small Grease Nipple |
| M Tie-rod | AE Tie-rod LH |
| N Steering Idler Arm Dust Seal "O" Ring | AF Nut |
| O Steering Idler Arm Nylon Bushing | AG Tie-rod Adjusting Tube Clamp |
| P Nut | AH Bolt |
| Q Steering Idler Arm Washer | AI Tie-rod Adjusting Tube |
| R Cotter Pin | AJ Knuckle Stopper Bolt |
| S Steering Relay Rod | AK Nut |
| T Cotter Pin | AL Tie-rod End Plug |
| U Tie-rod End Screw Plug | AM Steering Knuckle LH Arm |

Removal

1. Remove pitman arm from sector shaft using Pitman Arm Puller (PT20 SST-2083).

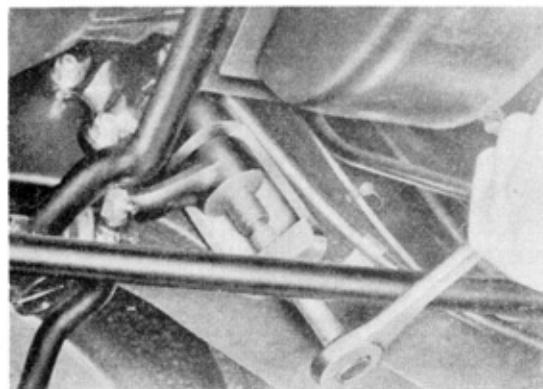

Fig. 8-38 Removing Pitman Arm

2. Remove steering idler arm support from body.
3. Remove knuckle arm knob nut and disconnect tie-rod end from knuckle arm using Tie-rod End Puller (PT20 SST-2083).

Installation

1. Connect tie-rod end to knuckle arm and after tightening nut install cotter pin.
Torque Spec. 4.2~6.2 m·kg (30~45 ft·lb)
2. Attach steering idler arm support to body.
Caution: When installing it, loosen nut so that idler arm may rotate freely in rubber bushing.
3. Install pitman arm to sector shaft, and after tightening nut install cotter pin.
Torque Spec.
14~14.5 m·kg (100~105 ft·lb)

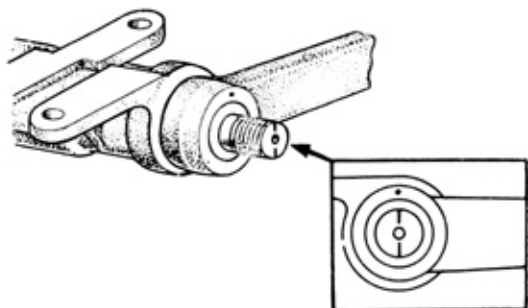

Fig. 8-39 Installing Pitman Arm

Caution: Match the mark on sector shaft with that of pitman arm.

4. With front wheels in straight ahead position, tighten nut attaching idler arm bushing and install cotter pin.

Torque Spec.

13~14.5 m·kg (95 - 105 ft·lb)

Disassembly

1. Remove pitman arm from relay rod using Tie-rod End Puller (PT20 SST-2083).
2. Disconnect tie-rod from relay rod using Tie-rod End Puller (PT20 SST-2083).
3. Disconnect relay rod from idler arm.
4. Remove idler arm from idler arm support.
5. Remove rubber bushing and inner pipe from idler arm support.
6. Remove tie-rod end from tie-rod.

Note:

Thread on Tie-rod Adjusting Tube

Tie-rod Side Right-hand Thread

Tie-rodEnd Side Left-hand Thread

7. Remove tie-rod end knob from tie-rod and relay rod. Remove cotter pin and tie-rod end screw plug, then disassemble tie-rod end spring, ball seat, end knob and end ball.

Inspection

1. Replace idler arm bushing or nylon bushing if they are worn, damaged or corroded.
2. Replace tie-rod end ball seat or knob if they are worn or damaged.
3. Replace tie-rod end spring if it is weakend.
4. Replace tie-rod end dust seal if it is corroded.
5. Replace tie-rod, tie-rod end, relay rod or idler arm if they are bent or damaged.

Assembly

1. Lubricate and assemble tie-rod end ball and tie-rod end knob at tie-rods and relay rod. Then assemble ball seat and spring as shown in the figure. Screw in tie-rod end screw plug tight and then unscrew about 1/2 turn.

Check to see that the knob turns smoothly without looseness. Insert cotter pin and lock the plug.

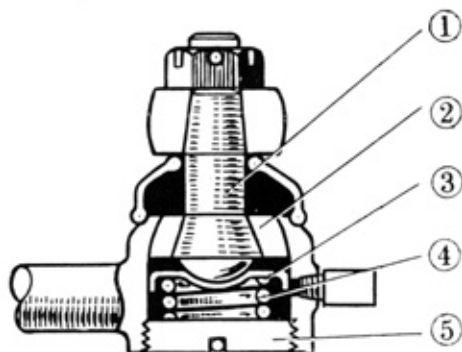

Fig. 8-40 Assembling Tie-rod End

1. Knob
2. Ball
3. Ball Seat
4. Spring
5. Screw Plug

2. Install clamps on the adjusting tube, and screw adjusting tube in the tie-rod. Then screw tie-rod end into adjusting tube.

3. Connect tie-rod to relay rod with tie-rod end knob and tighten securely with nut. After tightening nut, install cotter pin.

Torque Spec. 4.2-5 m-kg (30-36 ft-lb).

4. Connet relay rod to pitman arm with tie-rod end knob and tighten securely with nut. After tightening nut, install cotter pin.

Torque Spec. 4.2-5 m-kg (30-36 ft-lb)

5. Insert rubber bushing into idler arm up to the shoulder.

The outer diameter of the rubber bushing is slightly larger than the inside diameter of the idler arm, so when inserting this bushing into the idler arm, apply soap water to the bushing.

6. Next, insert a guide into the end of the idler arm inner pipe and press the pipe

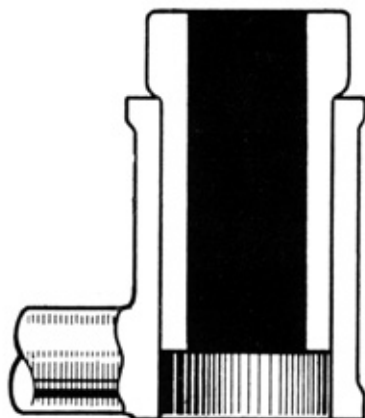

Fig. 8-41 Inserting Rubber Bushing

into the bushing. The pipe is provided with small teeth at both ends.

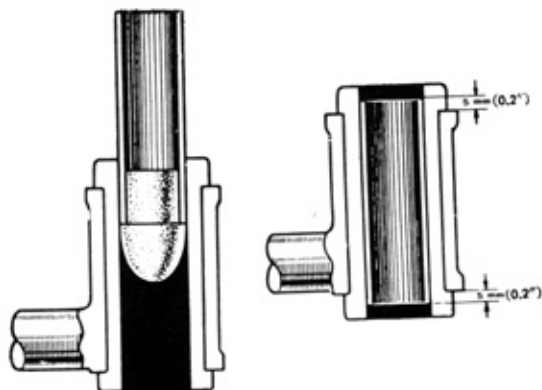

Fig. 8-42 Inserting Guide & Inner Pipe

7. Attach idler arm to idler arm support, and tighten nut loosely.

8. Connect relay rod to idler arm. After tightening nut, install cotter pin.

Torque Spec. 5.2-5.8 m-kg (38-42 ft-lb)

Caution: Lubricate nylon bushing with grease.